

MEDIUM LITHIUM BOX & LARGE LITHIUM BOX

HAIKI
— COBAT —

DAMAGED OR DEFECTIVE LITHIUM BATTERIES?

**FOR SAFE STORAGE
AND TRANSPORT,
THE SOLUTION IS
LITHIUM BOX.**

In some specific conditions, lithium batteries state can turn unstable. When a battery is in a critical condition, due to a manufacturing defect, a damage or an inappropriate storage, the biggest risk is thermal runaway, the main cause of fire.

To ensure storage and transport in total safety, Haiki Cobat has designed the Lithium Box line. Medium and Large versions are available, for different batteries sizes and energy capacities.



MEDIUM LITHIUM BOX

Box Lithium Medium is the innovative 4A metal container approved for the safe management of damaged or defective lithium batteries developed in Italy and certified in Germany by BAM, the Federal Institute for Materials Research and Testing, the competent authority in Germany for the packaging of dangerous goods appointed by the German Ministry of Transport.

Medium Box Lithium is designed for the storage and the transport of one or more damaged or defective lithium batteries in critical state that could evolve towards a thermal runaway, in accordance with special provision 376 and packing instruction P911 of the ADR Regulation.



TECHNICAL DATA

Component

1 base and 1 bell-shaped cover

Material

Steel with theraml insulating material

External dimension

2060 x 1552 x 800 mm

Internal dimension

1739 x 1211 x 495 mm

Tare

478 kg

Maximum capacity

400 kg

Internal volume

1 m³

Finishing

Paint

UN approved

4A/X945/S/.../D/BAM 15606-COBAT1

Stackable

Yes

Smoke and gas control system

Metallic activated carbon filters

Accessory kit included in the supply

2 bags of 100 l of vermiculite

1 antistatic bag of the size suitable for battery pack

2 insulating pillows to be placed on the base of the safety container and above the battery

5 fixing straps

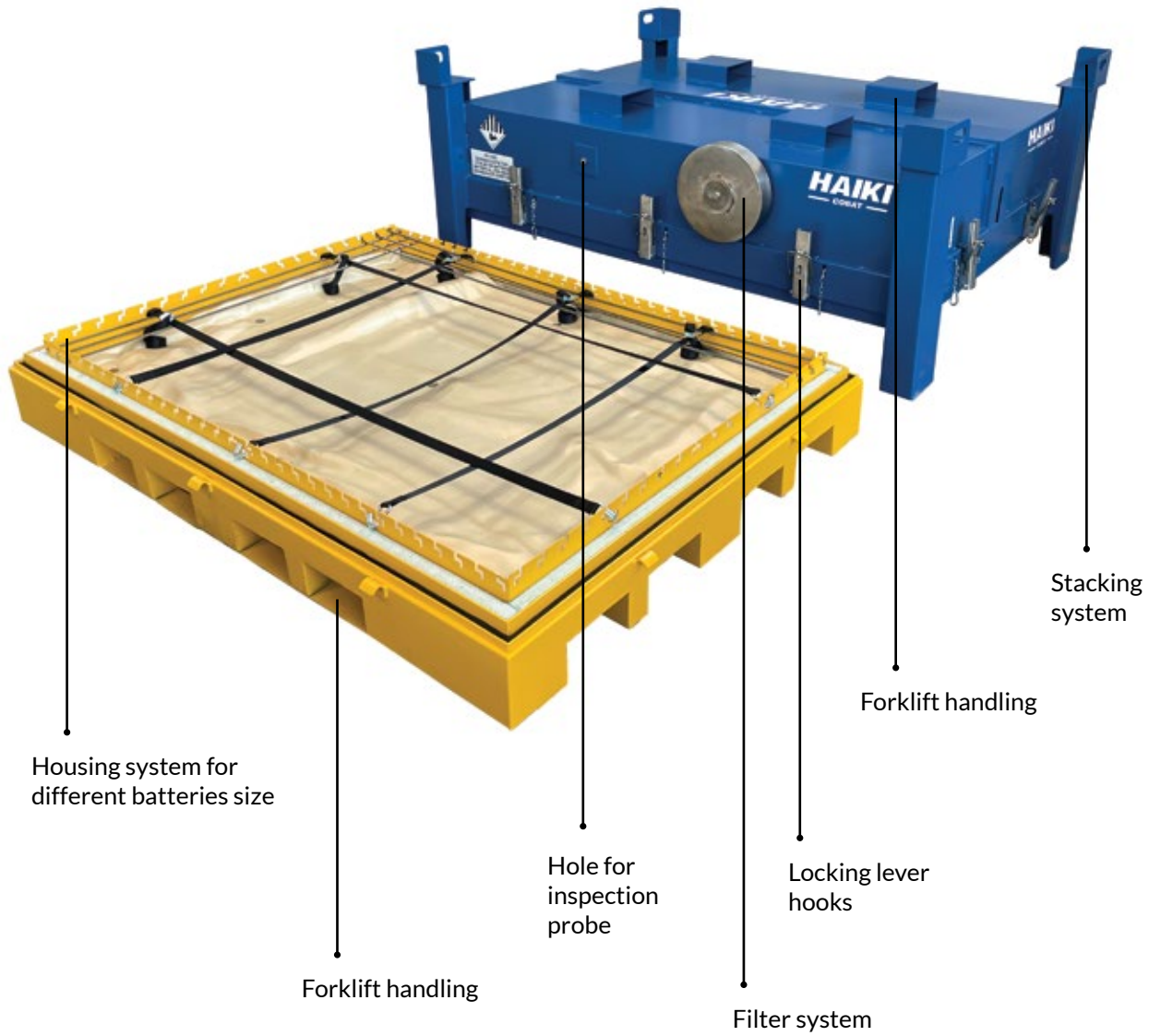

CONTAINER COMPONENTS:

1. Base
2. Insulating pillow Type A
3. Steel bars
4. Frame element
5. Insulating pillow Type B
6. Bell-shaped cover
7. Filters

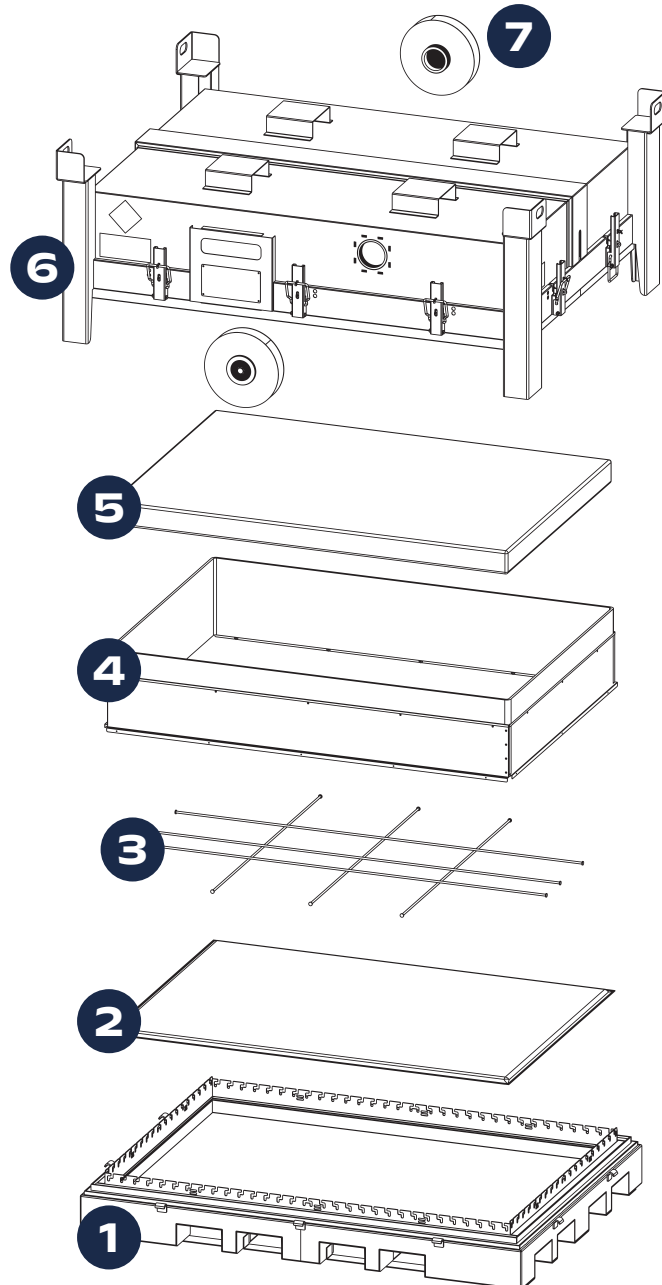



LARGE LITHIUM BOX

Box Lithium Large is the innovative 50A metal container approved for the safe management of damaged or defective large lithium batteries developed in Italy and certified in accordance with the Regulation published by the German Federal Institute for Materials Research (BAMGGR 024 Verfahren zur Erfüllung der zusätzlichen Prüfanforderungen für den Transport kritisch-defekter Lithiumbatterien).

Box Lithium Large is designed for the storage and the transport of one or more damaged or defective lithium batteries in critical state that could evolve towards a thermal runaway, in accordance with special provision 376 and packaging instruction P911 of the ADR Regulation.



TECHNICAL DATA

Structure

1 base and 1 bell-shaped cover

Material

Steel with thermal insulating material

External dimension

3194 x 2254 x 898 mm

Internal dimension

2650 x 1709 x 560 mm

Maximum capacity

1008 kg

Tare

1246 kg

Internal volume

2,78 m³

Finishing

Paint

UN approved

50A/X/.../D/BAM 15863-COBAT1

Stackable

Yes

Smoke and gas control system

Activated carbon filters

Accessory kit included in the supply

4 bags of 100 l of vermiculite

1 antistatic bag of the size suitable for battery pack

4 insulating pillows to be placed on the base of the safety container and above the battery

9 fixing straps

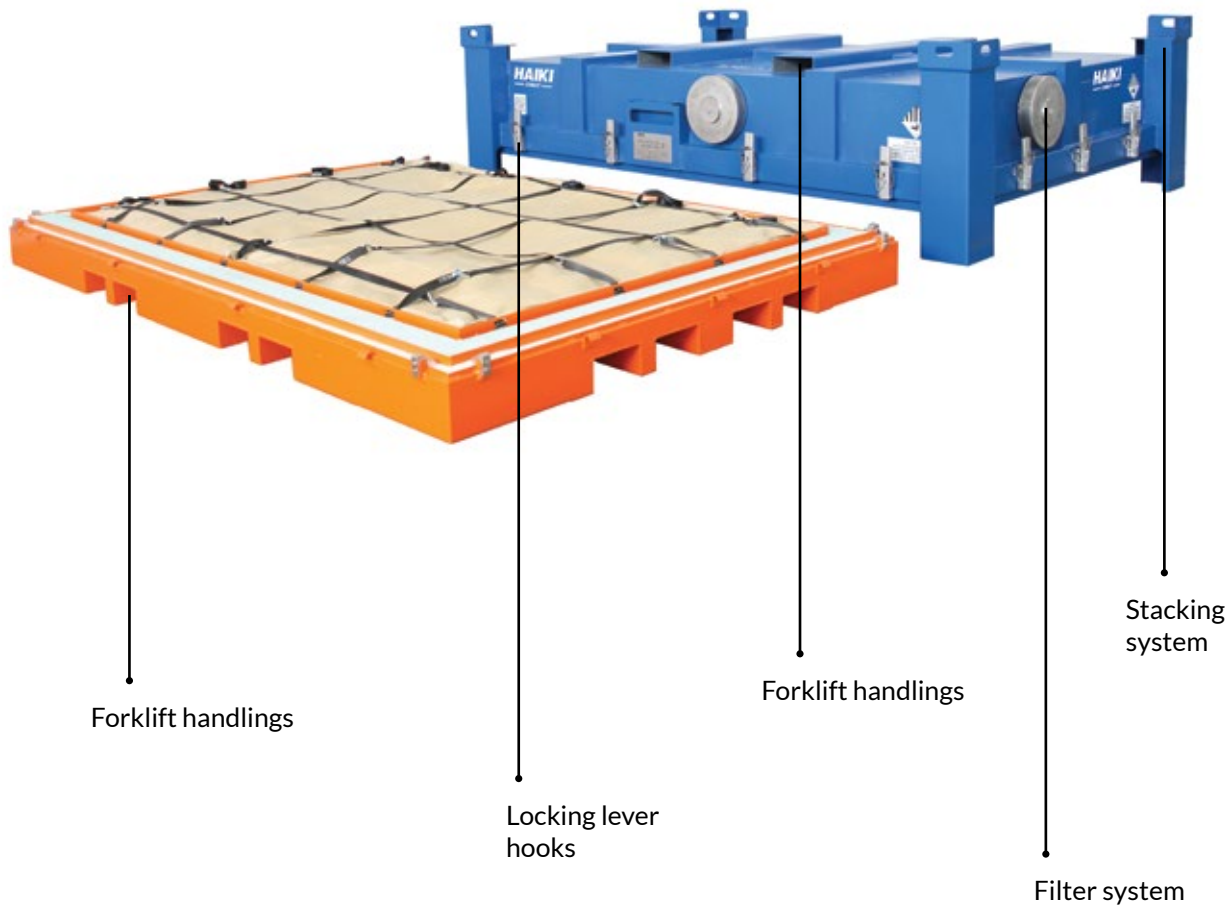

**CONTAINER
COMPONENTS:**

1. Base
2. Insulating pillows Type A
3. Frame element
4. Insulating pillows Type B
5. Bell-shaped cover
6. Filters

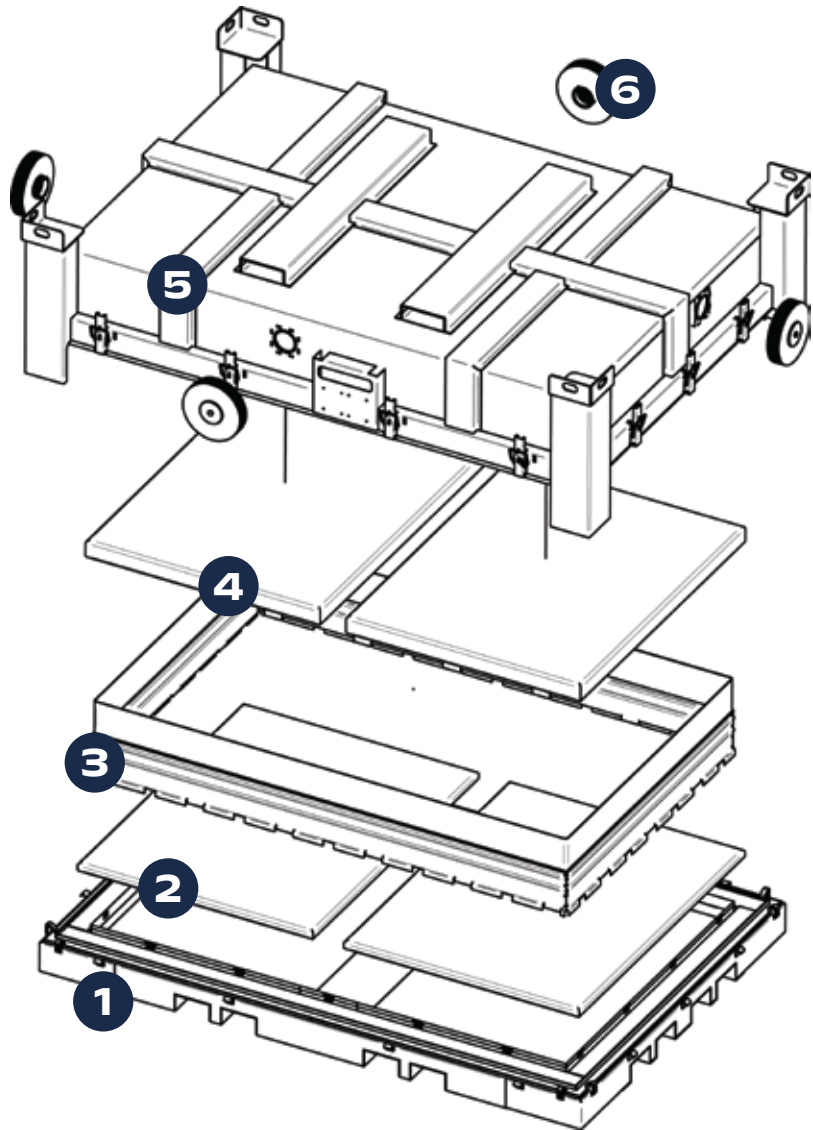

Haiki Cobat SpA SB

Via Vicenza 29 - 00185 Roma
www.cobat.it | www.haikiplus.it